

SECTION A-A

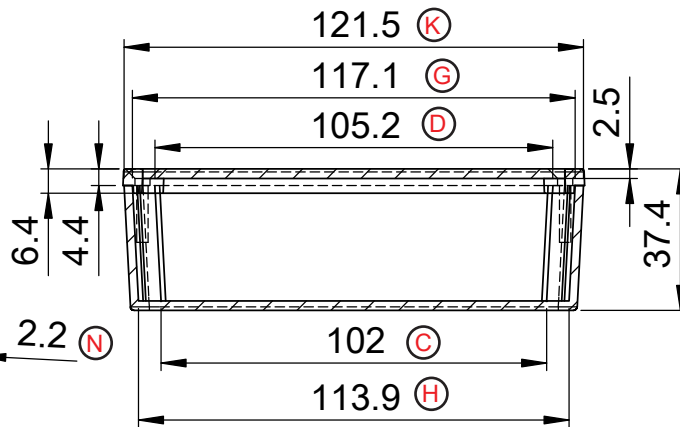

SECTION B-B

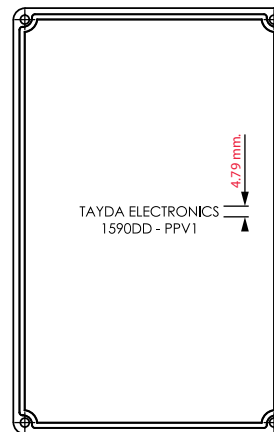
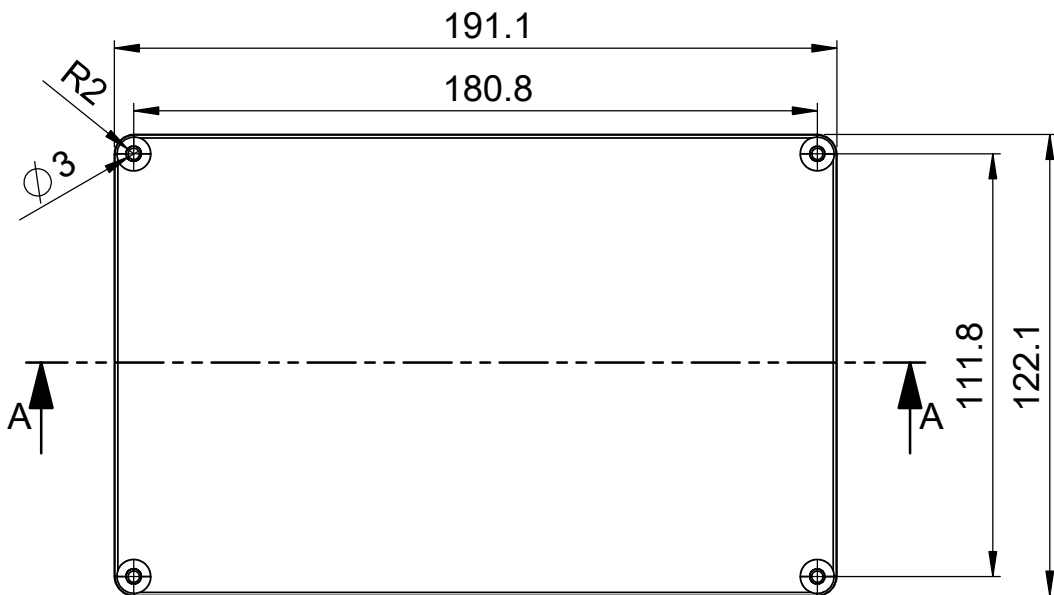
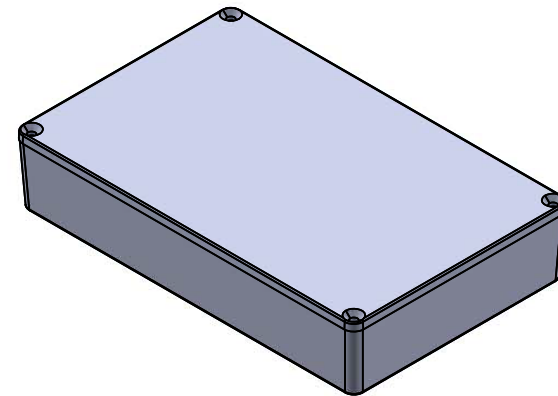

PART NO. : 5141
 SKU: A-5141
 1590DD

Lid
 AL mass = 179 g.
 Body
 AL mass = 267 g.

Note : Logo under the lid " TAYDA ELECTRONICS 1590DD - PPV1 "

General Tolerance
0 = ±0.50
0.0 = ±0.10
0.00 = ±0.02
Unspecified radius : R0.5
Tolerance on angle ±1°

PART NO.	PART NAME	OVERALL MEASURE	QTY	MATERIAL	HARDNESS
DESIGNED BY		FIRST ANGLE PROJECTION	TAYDA ELECTRONICS		
CHECKED BY					
APPROVED BY					
CUSTOMER		Unit mm.	DWG NO.	REVISION	
		SCALE:1:2	DATE 6/6/2024	SHEET 1 OF 2	
			FILE box 5141		