

CRYSTAL UNIT SPECIFICATIONS

Customer	ADS
Customer P/N	
Product	49SMA CRYSTAL
Nominal Frequency	11.059200MHz
HOSONIC P/N	E49B11E0X000RE
Version	10C0
Issue Date	2015/4/25

HOSONIC		
Drawn	Checked	Approved
LUCY	ZOE	JOHN

Approved By Customer : _____



HOSONIC ELECTRONIC CO., LTD.



Revised Record

Rev.	Rev. Date	Item	Content	Remark
1.0	2015-04-25		Initial released	

I ELECTRICAL PARAMETERS

No.	Item	Symb.	Electrical Specification				Remark
			Min.	Typ.	Max.	Units	
1	Nominal Frequency	F0	11.059200			MHz	
2	Mode of Vibration		Fundamental				
3	Frequency Tolerance	$\Delta F/F0$	-30	-	30	ppm	at 25°C±3°C
4	Operating Temperature Range	T _{OPR}	-40	-	85	°C	
5	Frequency Stability	TC	-30	-	30	ppm	Ref. to 25°C
6	Storage Temperature	T _{STG}	-55	-	125	°C	
7	Load capacitance	CL	-	16	-	pF	
8	Equivalent Series Resistance	ESR	-	-	50	Ω	
9	Drive Level	DL	-	100	500	μW	
10	Insulation Resistance	IR	500	-	-	MΩ	At 100V _{DC}
11	Shunt Capacitance	C0	-	-	7	pF	
12	Aging Per Year	Fa	-5	-	5	ppm	First Year
13	Package type	HC-49SMA					

NOTE: Storage Temperature is only for the product itself, the temperature for the packing material is -4~40°C.

I REFLOW PROFILES

Profiles Feature	Pb-Free Assembly
Average Ramp-up Rate (Ts max to Tp)	3°C/second max.
Preheat <ul style="list-style-type: none"> ■ Temperature Min (Ts min) ■ Temperature Max (Ts max) ■ Time (ts min to ts max) 	125°C 200°C 60~180 seconds
Time maintained above <ul style="list-style-type: none"> ■ Temperature (T_L) ■ Time (t_L) 	217°C 60~150 seconds
Peak/Classification Temperature (Tp)	260°C
Time within 5°C of actual Peak Temperature (t _p)	20~40 seconds
Ramp-down rate	6°C/second max.
Time 25°C to Peak Temperature	8 minutes max.
Suggest reflow times	3 Times max

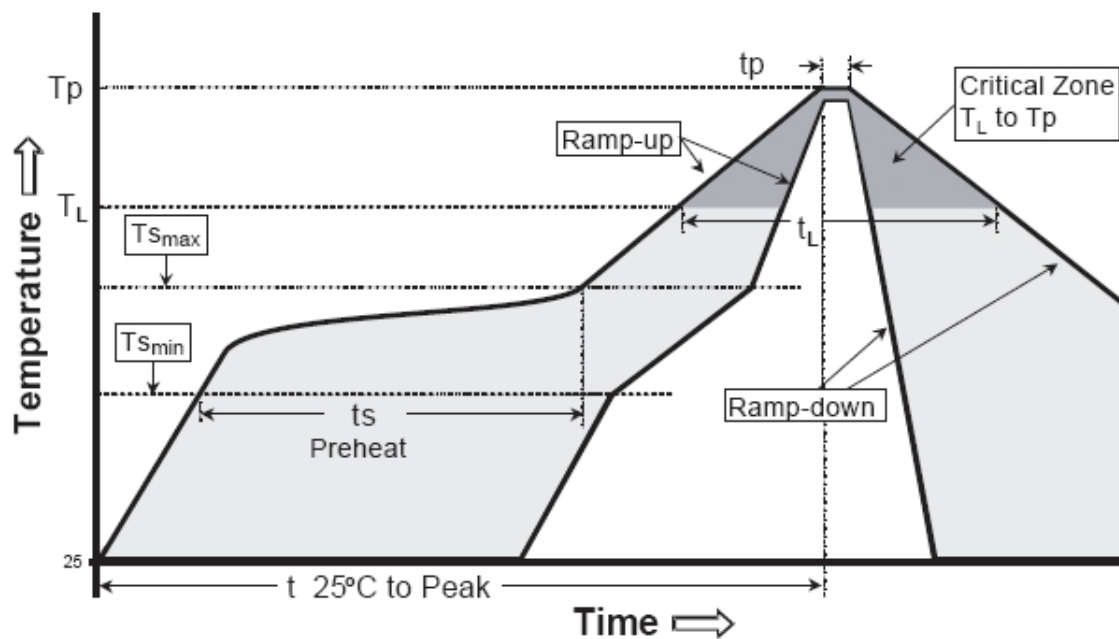

Remark: To reference JEDEC J-STD-020C

I OUTLINE DIMENSIONS (unit: mm)

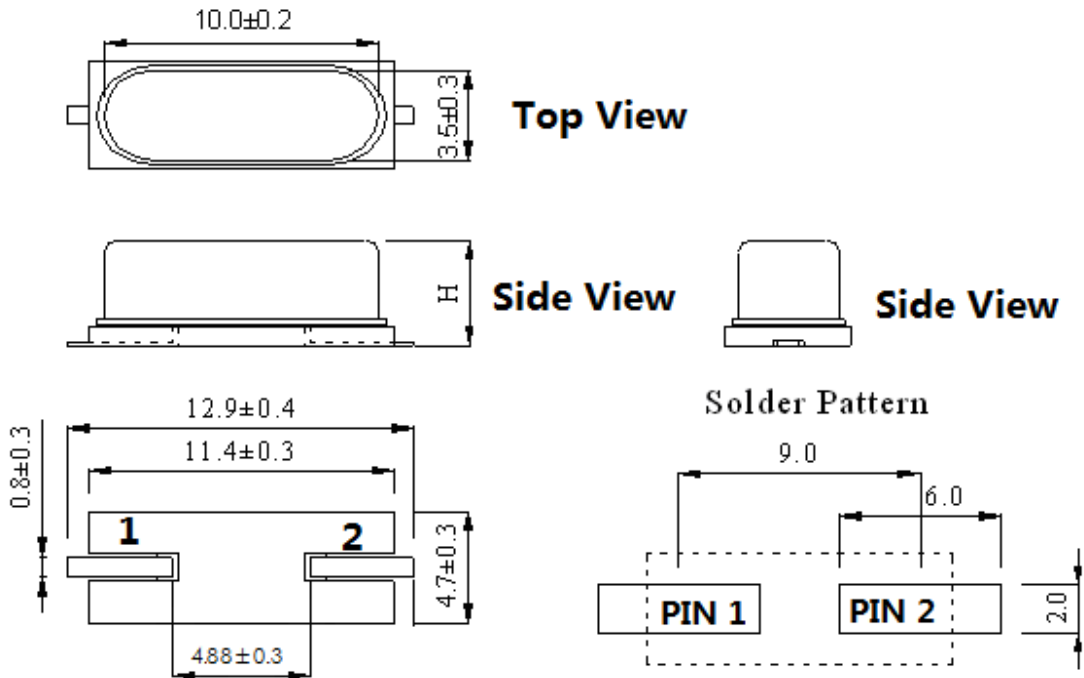

$H = 4.2\text{Max}$

I MARKING

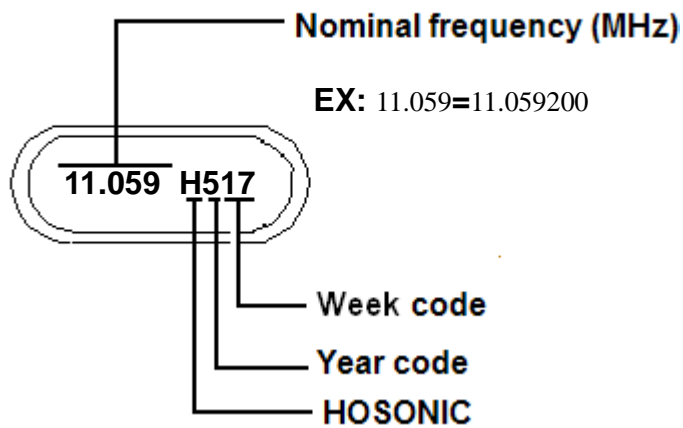

I PACKAGE (units : mm) (reference to EIA-481)

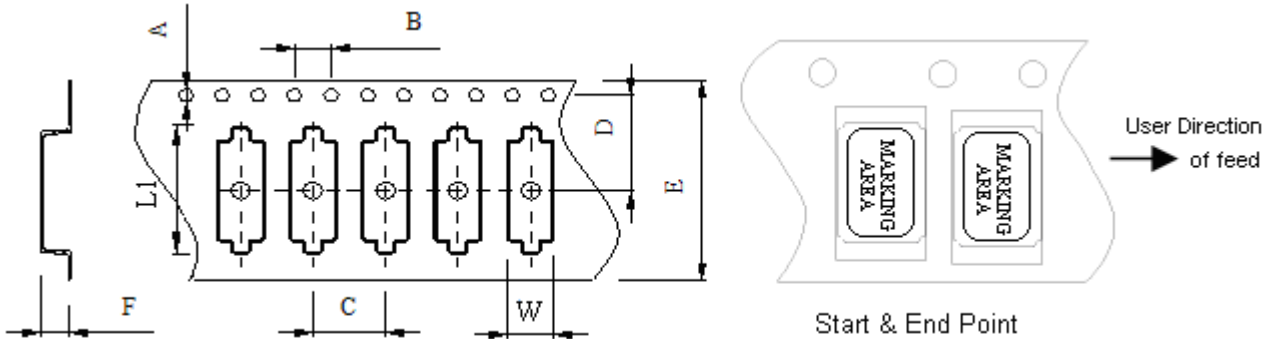

Model	A	B	C	D	E	F	L1	W
HC-49SMA	$\Phi 1.50 \pm 0.2$	4.0 ± 0.2	12 ± 0.1	11.5 ± 0.2	24 ± 0.3	4.35 ± 0.1	15 ± 0.1	5.1 ± 0.1
HC-49SMB	$\Phi 1.50 \pm 0.2$	4.0 ± 0.2	12 ± 0.1	11.5 ± 0.2	24 ± 0.3	3.5 ± 0.1	15 ± 0.1	5.1 ± 0.1

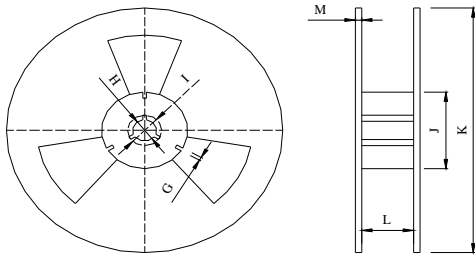

***1000pcs/Reel**

Model	G	H	I	J	K	L	M
HC-49SMA	2.4 ± 0.1	$\Phi 13.5$	20 ± 0.1	100 ± 0.1	330 ± 0.1	25.5 ± 0.1	2.1 ± 0.1
HC-49SMB	2.4 ± 0.1	$\Phi 13.5$	20 ± 0.1	100 ± 0.1	330 ± 0.1	25.5 ± 0.1	2.1 ± 0.1

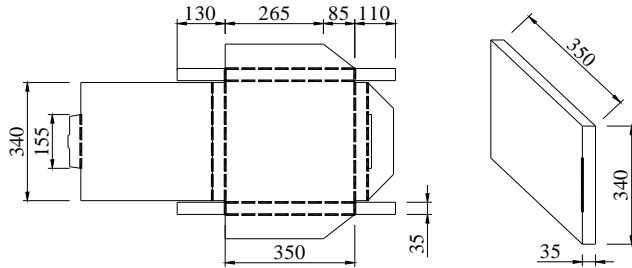
I PACKAGE (units : mm) (Continued)

Notes:

1 units: mm

2 --- 折痕

1 REEL = 1 INNER BOX

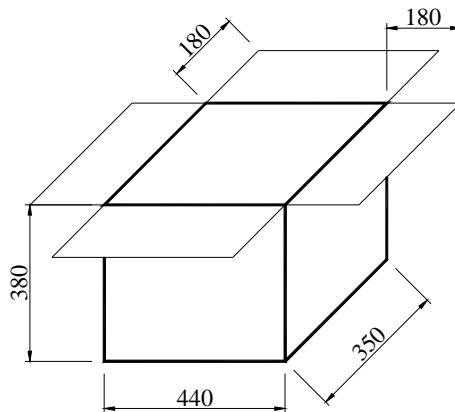
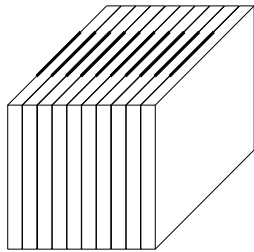

10 INNER BOX = 1 OUTER BOX

10,000 pcs = 1 OUTER BOX

I RELIABILITY SPECIFICATIONS

No.	Test Item	Test Conditions	Reference
1	High Temperature Storage	Temperature: 125°C ± 5°C Time: 1000 ± 12 Hours	MIL-STD-883E-1016
2	Temperature Cycle	Temperature 1: -55°C ± 5°C Temperature 2: 125°C ± 5°C Temperature change between T1 and T2 at soonest Run 1000 cycles, maintain T1 and T2 5minutes each in one cycle	JESD22 Method JA-104
3	Solder Heat Resistance	Pre-heat: 125°C 60~120 Seconds Solder Temperature: 260°C ± 5°C Time: 30 Seconds	MIL-STD-202F 210 E
4	Drop Test	3 Times Free Fall from 75cm height table to 3cm thickness hard wood board	MIL-STD-202F-203B
5	High Temperature, High Humidity Storage	Temperature: 85°C ± 5°C Relative Humidity: 80%~85% Time: 250Hours ± 24 Hours	MIL-STD-202F-103B
6	Steam Aging	Temperature: 97°C ± 5°C Time: 24 Hours 260°C solder pot to check solderability	MIL-STD-883 C-1008.2B
7	Solderability	Dip in flux 5~10 seconds Temperature: 245°C ± 5°C Time: 10 Seconds	MIL-STD-202F-208H
8	Aging	Temperature: 85°C ± 5°C Time: 250 ± 12Hours	MIL-STD-202 F-108A
9	Thermal Shock	Temperature 1: -55°C ± 5°C Temperature 2: 125°C ± 5°C Temperature change between T1 and T2: 5 seconds 100 cycles, maintain T1 and T2 for 30 minutes each in one cycle	MIL-STD-883E-1011.9B
10	Vibration	Frequency Range: 10Hz~2000Hz Amplitude: 1.5mm or 20G 4Hours in each direction, total 12Hours	MIL-STD-202F-204D