



TABLE OF CONTENTS

	Page
EIA Temperature Characteristic	2
 MLCC RADIAL & AXIAL	
Class I	3
Class II, III	4
Range Chart (Radial)	5
Mechanical specification (Radial)	6
Packing specification (Radial)	7
Range Chart (Axial)	8
Mechanical specification (Axial)	9
Packing specification (Axial)	10
Part number system	11
 CERAMIC DISC	
Class I	12
Class II	13
Class III	14
Range chart	15,16
Mechanical specification	17
Low D.F. type	18
Packing specification	19
Part number system	20
 SAFETY DISC (AC CAPACITOR)	
Approval license and file number	21
Range chart V.S. body size	22
Part number system	23



EIA Temperature Characteristic

Class I

(Table 1)

EIA code	Material Coefficient	Temperature Coefficient
C0	NPO	
S1	N030	G:±30
U1	N080	H:±60
P2	N150	J:±120
R2	N220	K:±250
S2	N330	L:±500
T2	N470	
U2	N750	
P3	N1500	
R3	N2200	M:±1000
S3	N3300	
T3	N4700	

- * For multilayer radial leaded type COG (NPO) is standard.
- * For disc leaded type SL T.C. range will be P350-N1000
- * T.C. Tolerance in PPM/°C
- * Recommend COG (C0H) , U2J . SL are Standard Types.

Class II, III

(Table 2)

First digit is Low temperature	Second digit is high temperature	Last digit is capacitance change over temperature range from 25°C reading
X: -55°C	4: +65°C	A:±1. 0% P:±10%
Y: -25°C	5: +85°C	B:±1. 5% R:±15%
Z: +10°C	6: +105°C	C:±2. 2% S:±22%
	7: +125°C	D:±3. 3% T:+22%, -33%
	8: +150°C	E:±4. 7% U:+22%, -56%
		F:±7. 5% V:+22%, -82%

Class I

Temperature Compensating Capacitors have a ceramic dielectric that is formulated to provide a predicable linear capacitance change versus temperature. This predicable linear capacitance change allows to be used in critical circuit applications such as tuned circuit.

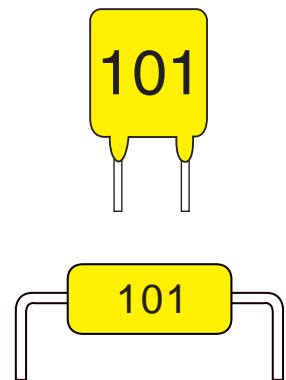

Q-chart

1. NPO-N1500 initial
2. Over N1500 initial
3. NPO-N1500 after life & humidity
4. Over N1500 after life & humidity

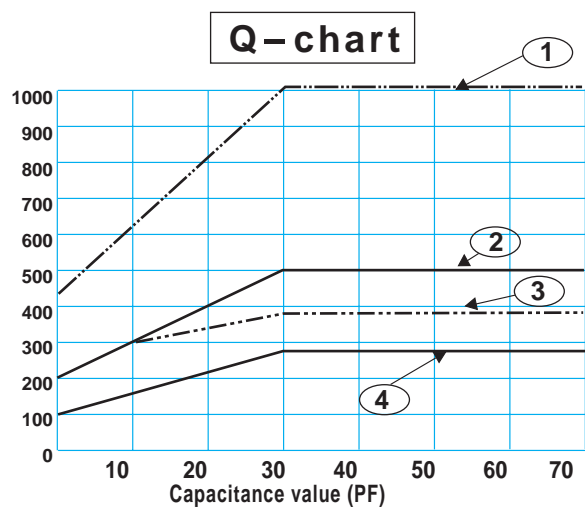

Electrical Specification

Item	Specification	Testing method
Capacitance	To be within the spec. tolerance.	shall be measured at $25 \pm 1^\circ\text{C}$, $1.0 \pm 0.2 \text{ Vrms}$ and 1 MHz, 1 KHz for value above 1000 pf.
Dissipation factor	$C > 30\text{pf}$, DF:0.1% max $C \leq 30\text{pf}$, $Q = 400 + 20C$ min	
Insulation resistance	Cap. $\leq 10\text{nF}$: $I.R \geq 100\text{G}\Omega$	shall be measured 60 ± 5 sec, at rated voltage.
Dielectric strength	To be within the 250% rated voltage.	With 50 mA (max) charging current.



Class II, III

The HI-K (Dielectric constant) capacitor, the maximum capacitance can be controlled in tolerance when the temperature is over 25°C. The general application in circuit where a large amount of capacitance is required but less sensitive to change with temperature variation such as “coupling” , “by pass” circuit.

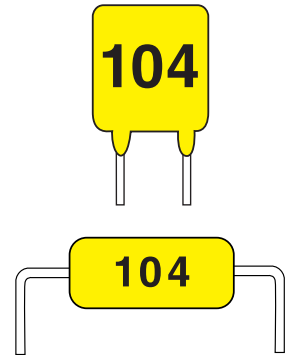

Electrical Specification

Item	Specification	Testing method
Capacitance	To be within the spec. tolerance.	shall be measured at 25±1°C, X7R, Y5V:1.0±0.2V and 1KHz Z5U : 0.5V±0.1 and 1KHz
Dissipation factor	X7R : 2.5%max Z5U : 4%max Y5V : 5%max	
Insulation resistance	Cap.≤10nF: I.R≥100GΩ Cap.>10nF: I.R≥1000MΩ - μF	shall be measured 60±5 sec, at rated voltage.
Dielectric strength	To be within the 250% rated voltage.	With 50 mA (max) charging current.

Reliability testing:

	Item	Specification	Testing method
Humidity test	Appearance	No damage	Temperature:40±2°C Relative humidity:90%~95% Duration:500+24/-0 hrs Test step: a..oven dry at 40±5°C for 24 hrs. b..take required measurement as specified. c..subject specimens to test. d..final measurement at room condition for not less than 2 hours unless otherwise specified.
	Capacitance	Capacitance change NPO:±2% or 1.0pF X7R:±20% Z5U,Y5V:±30%	
	Dissipation factor	Dissipation factor change NPO:0.5% max X7R,Z5U:5% max Y5V:7.5% max	
	Insulation Resistance	Cap.≤10nF: I.R≥10GΩ Cap.>10nF: I.R≥100MΩ - μF	
Life test	Appearance	No damage	Ambient temperature:85±2°C Applied voltage:200% the rated voltage Duration:1000 + 48/-0 hrs Charging and discharging current shall be limited to 50 mA (max). Deaging at 150°C for 2 hrs and recover 24 hrs before measure. (NPO unnecessary)
	Capacitance	Capacitance change NPO:±2% or 1.0pF X7R,Z5U:±20% Y5V:±30%	
	Dissipation factor	NPO:0.5% max X7R,Z5U:5% max Y5V:7.5% max	
	Insulation Resistance	Cap.≤10nF:I.R≥10GΩ Cap.>10nF:I.R≥100MΩ - μF	



Range Chart:

NPO (COG) SERIES

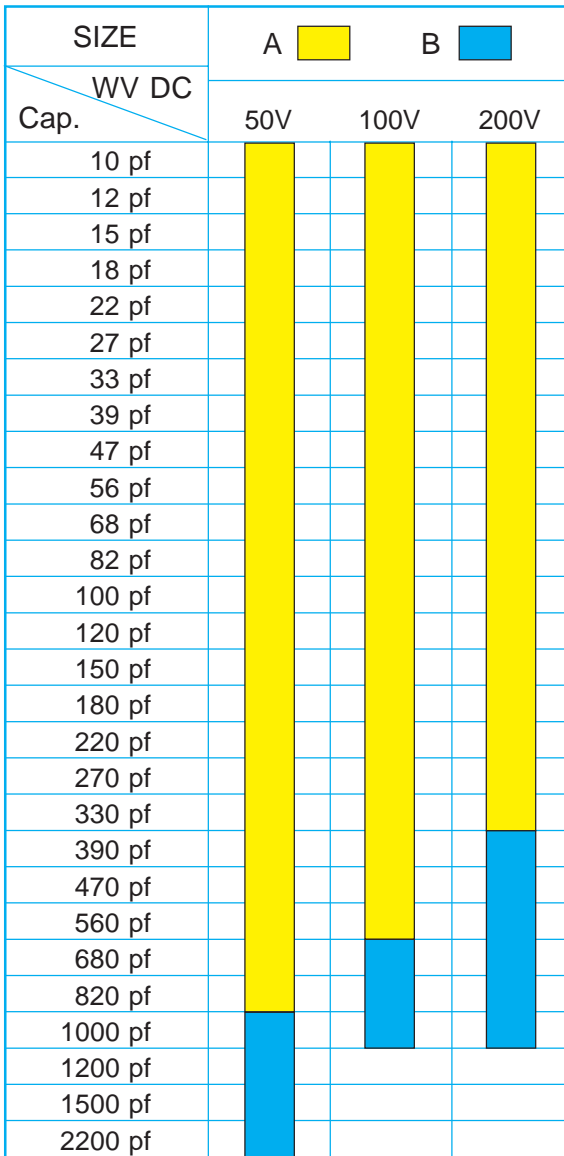

X7R SERIES

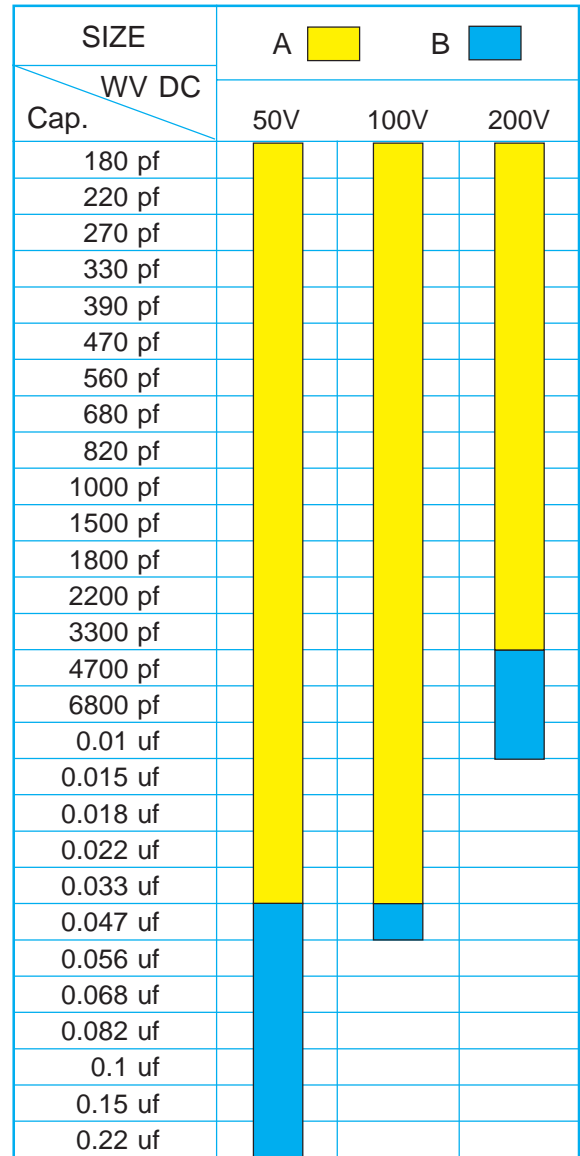

Z5U SERIES

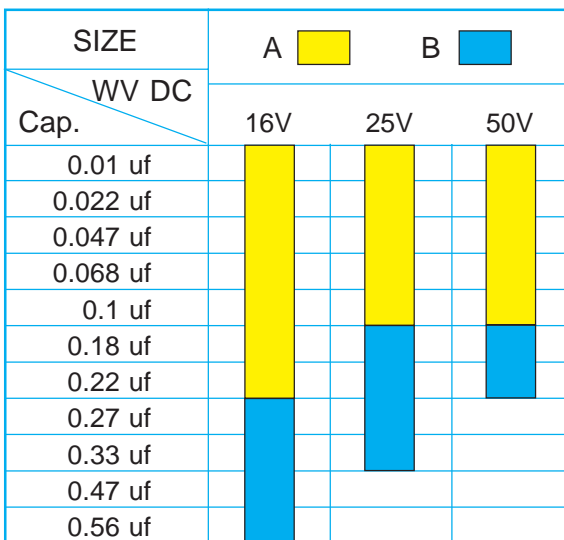

Y5V SERIES

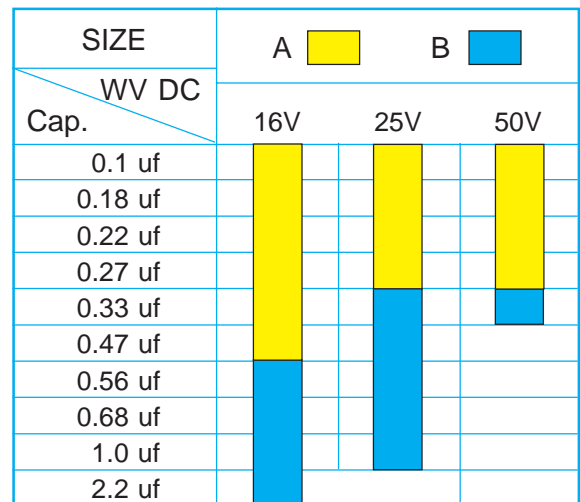

Mechanical specification

	Specification	Test condition
Marking	To be clear and legible.	Marking shall be tested with Acetone.
Terminal strength	Tensile Strength: No Breakdown	Wire dia. 0.55 mm, loading weight 1.0 Kg for 10±1 seconds
	Bending strength: No Breakdown	Wire dia. 0.55 mm, loading weight 0.5 Kg (Bend back and forth 90 degree twice)
Solder ability	Lead wire to be soldered up to the dipped end point, with no gap in the axial direction, over 3/4 of the circumferential direction.	Solder temperature : 235±5°C Dipping : 2±0.5 sec Flux shall be used.

Construction

1. Ceramic Dielectric
2. Electrodes
3. Metalized end
4. Solder
5. c.p. wire
6. Epoxy resin encapsulant

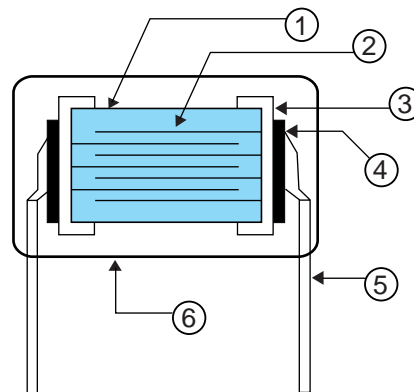

Dimension

Dimension in mm

Lead Style	Side Code	Pitch (F)±0.5	Length (L) Max.	Width (W) Max.	Thick (T) Max.	Seat Height (M) Max.	Lead Length (A)
H	A	5.08	3.81	3.81	2.54	2.54	Standard Long Lead: 25±1.0
	B	5.08	5.08	5.08	3.18	2.54	
K	A	2.54	3.81	3.81	2.54	3.50	Standard Short Lead: 3±0.5
	B	2.54	5.08	5.08	3.81	3.50	
	B	5.08	5.08	5.08	3.81	3.50	
L	A	2.54	3.81	3.81	2.54	1.00	4±0.5
	B	2.54	5.08	5.08	3.81	1.00	5±0.5

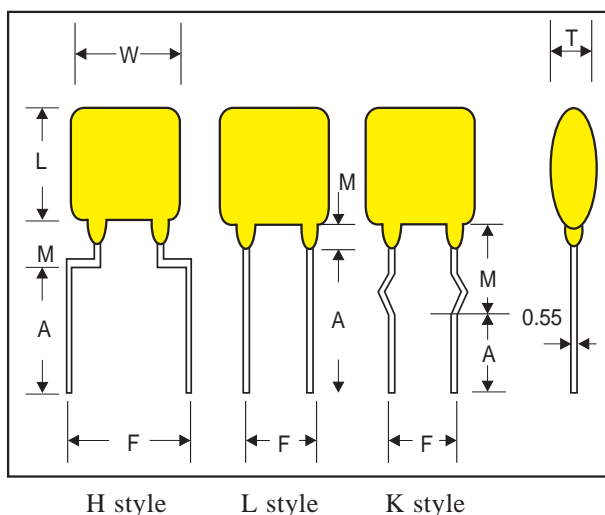

Marking principle:

1. Normal capacitance
2. Temperature characteristic
3. Working voltage
4. Capacitance tolerance

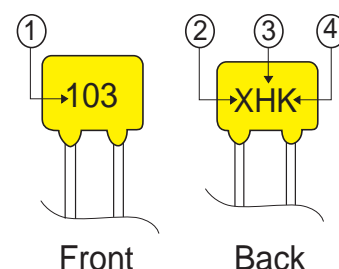



Packing Specification

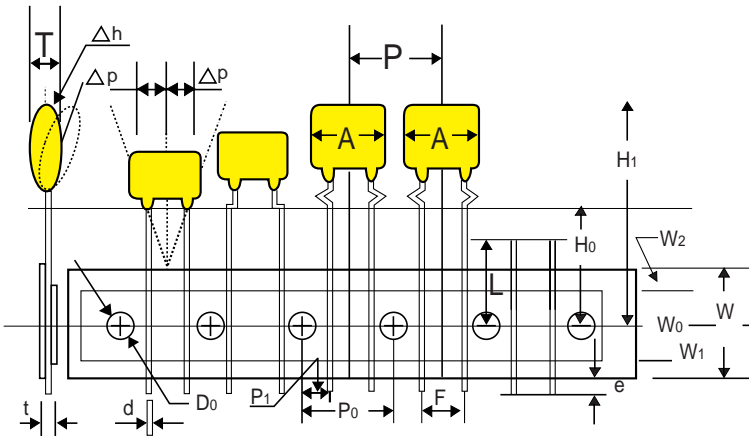

		unit:mm	unit:inch
Body Dimension	A	11.0*11.0 Max	0.43*0.43 Ref
Body Thickness	T	4.0 Max	0.157 Ref
Wire Lead Dia.	d	0.55±0.05	#24 AWG
Taping Pitch	P	12.7 Ref	0.05 Ref
Feed Hole Pitch (Note:1)	P0	12.7±0.3	0.5 Ref
Plane Deviation	ΔP	+1.0 Max	0.0394 Ref
Feed Hole Off Alignment	(2e) P1	3.81±0.7	0.15 Ref (F=5.08)
	(1e) P1	5.08±0.7	0.20 Ref (F=2.54)
Lead Spacing	F	5.08±0.5	0.2 Ref
	F	2.54±0.5	0.10 Ref
Body Inclination	Δh	0±1.0	0±0.39 Ref
Carrier Tape Width	W	18.0±1.0/-0	0.709 Ref
Adhesive Tape Width	W0	13.0 Ref	0.512 Ref
Feed Hole Ht Off Alignment	W1	9.0+0.75/-0.5	0.354 Ref
Adhesive Tape Width	W2	3.0 Ref	0.118 Ref
Straight Lead Height (Note:2)	H	20.0±0.5	0.787 Ref
Lead Crimp Height	H0	16.0 or 18.0±0.5	0.63 Ref
Top of Component Height	H1	32.0 Max	1.20 Ref
Lead End Protrusion	e	1.0 Max	0.039 Ref
Feed Hole Diameter	D0	4.0±0.3	0.157 Ref
Overall Tape Thickness	t	0.9 Max	0.035 Ref
Rejected Component Cut Height	L	10.0 Max	0.394 Ref

- Note : 1. Cumulative pitch tolerance over 20 consecutive units not to exceed ±1.0 mm
 2. H=20.0±0.5 for lead style. L, Ho=16 or 18.0±0.5 mm for lead style K.H
 3. Dimensions meet requirement defined in EIA RS468

Package quantity

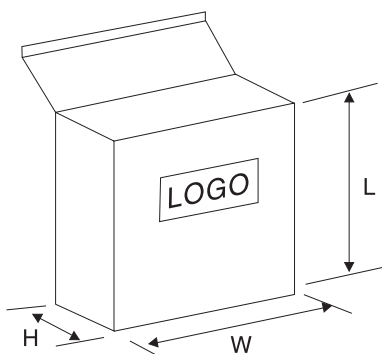

SIZE	Tape-Ammo	Bulk
	PCS/BOX	PCS/BAG
A	2000	1000
B	2000	1000

BOX SIZE:
 330*250*50mm(W*L*H)



Range Chart:

NPO (COG) SERIES

SIZE	35	50
WV DC	50V	
Cap.		
10 pf		
12 pf		
15 pf		
18 pf		
22 pf		
27 pf		
33 pf		
39 pf		
47 pf		
56 pf		
68 pf		
82 pf		
100 pf		
120 pf		
150 pf		
180 pf		
220 pf		
270 pf		
330 pf		
390 pf		
470 pf		
560 pf		
680 pf		
820 pf		
1000 pf		
1200 pf		
1500 pf		
1800 pf		

X7R SERIES

SIZE	35	50
WV DC	50V	
Cap.		
180 pf		
220 pf		
270 pf		
330 pf		
390 pf		
470 pf		
560 pf		
680 pf		
820 pf		
1000 pf		
1500 pf		
1800 pf		
2200 pf		
3300 pf		
4700 pf		
6800 pf		
0.01 uf		
0.015 uf		
0.018 uf		
0.022 uf		
0.033 uf		
0.047 uf		
0.056 uf		
0.068 uf		
0.082 uf		
0.1 uf		
0.15 uf		
0.22 uf		

Z5U SERIES

SIZE	35	50
WV DC	25V	50V
Cap.		
0.01 uf		
0.022 uf		
0.047 uf		
0.068 uf		
0.1 uf		
0.15 uf		
0.22 uf		
0.33 uf		
0.47 uf		
0.56 uf		
1.0 uf		

Y5V SERIES

SIZE	35	50
WV DC	25V	50V
Cap.		
0.1 uf		
0.18 uf		
0.22 uf		
0.27 uf		
0.33 uf		
0.47 uf		
0.56 uf		
0.68 uf		
1.0 uf		
2.2 uf		

Mechanical specification

	Specification	Test condition
Marking	To be clear and legible.	Marking shall be test with Acetone.
Terminal strength	Pull force ≥ 2 lb	Pull both lead ends till body broken
Solder ability	Lead wire to be soldered up to the dipped end point, with no gap in the axial direction, over 3/4 of the circumferential direction.	Solder temperature : $235\pm 5^{\circ}\text{C}$ Dipping : 2 ± 0.5 sec Flux shall be used.

Construction

1. Ceramic dielectric
2. Internal electrode
3. Terminal end
4. Solder paste
5. Epoxy resin encapsulant
6. Lead wire

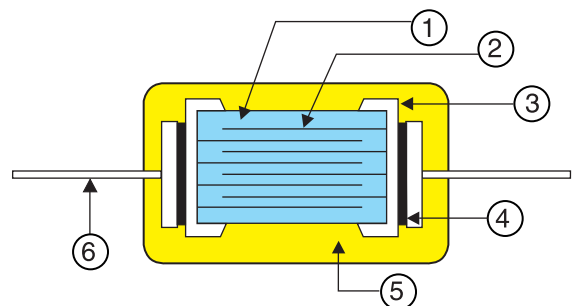

Marking principle & Dimension

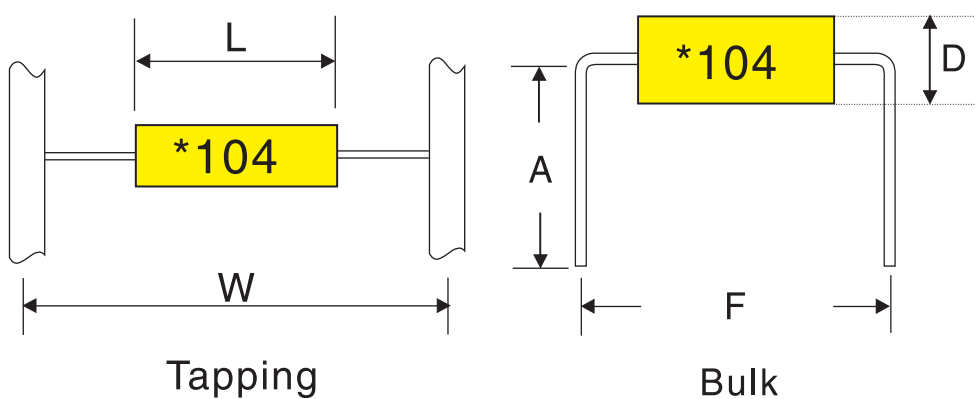

* Marking normal capacitance

(In mm)

SIZE	T (max)	D (max)	Tapping	BULK	
			W (mm)	F	A
35	3.5	2.5	26	5	5
50	5.0	3.0	52	NA	↓ 10

Tapping specification

Dim Unit	p	t	w	d
mm	5 ±0.5	6 ±0.5	26 52	1.2 max

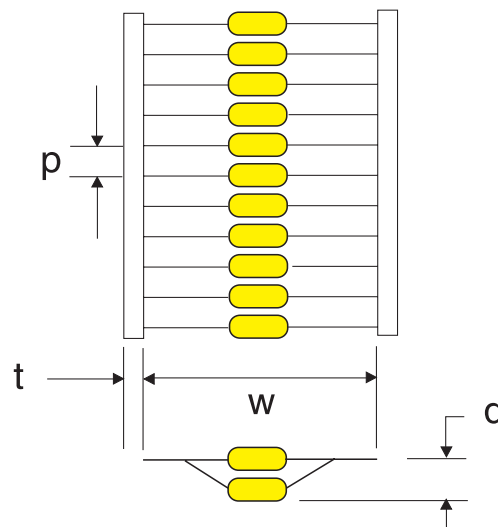

Packing specification

Dim Unit	L	W	H
mm	258	80	95

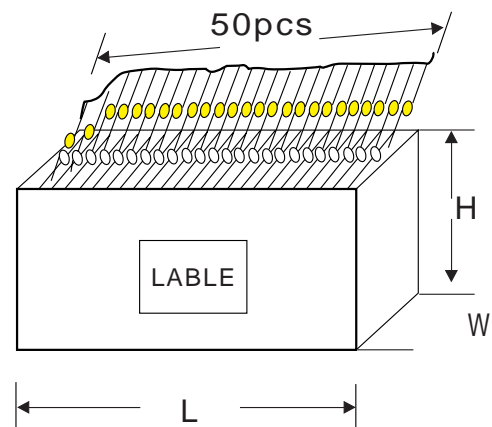

Package quantity

	(pcs)	
SIZE	35	50
Ammo	5000	5000
Bulk	1,000/PE bag	



Part number system

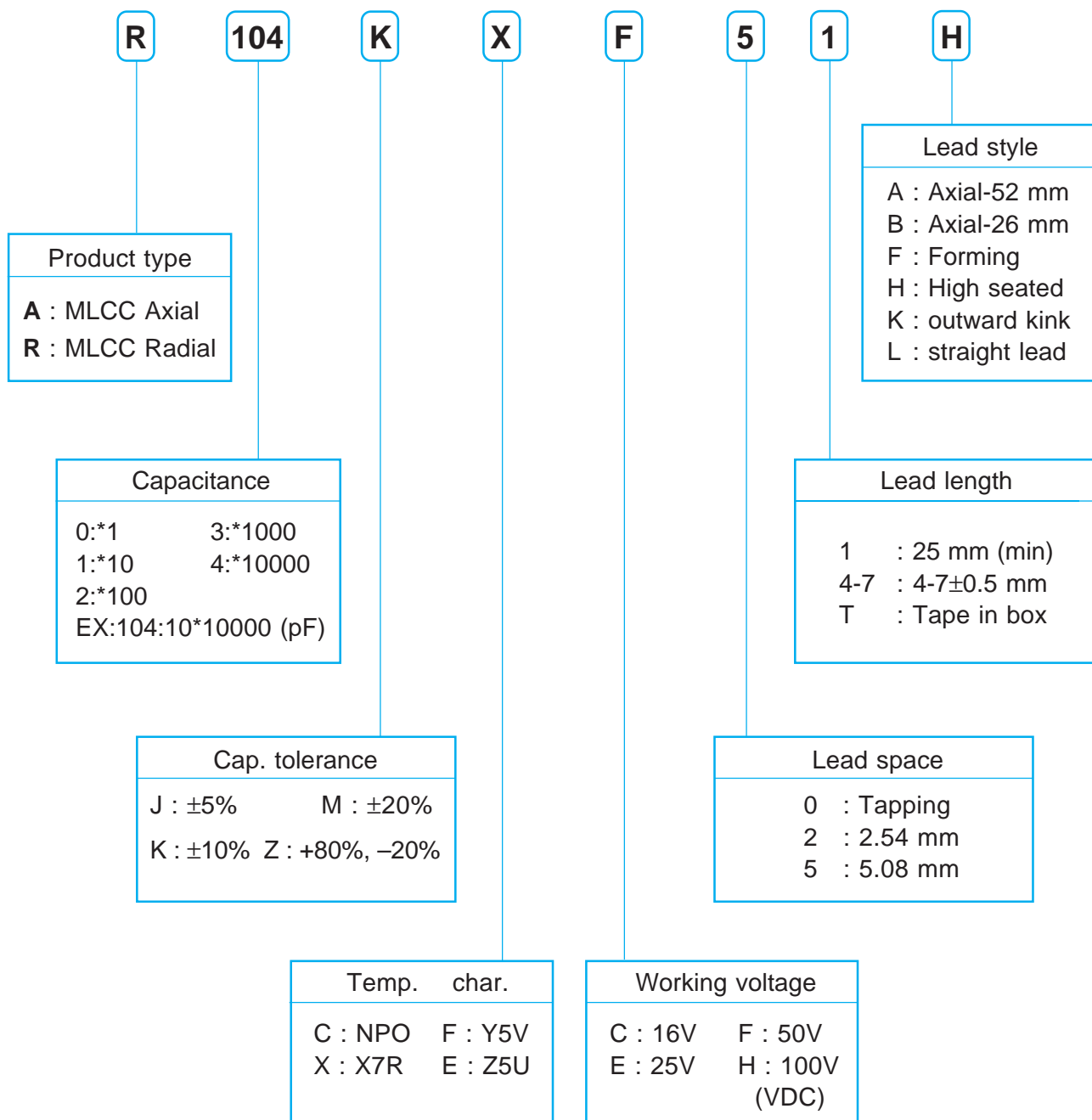

*Please contact with us if your design has a special requirement.



Temperature Compensating (TC) Capacitors 50 (160) ~ 6000WVDC

EIA RS 198 (Class I)
 JIS C 6423 (Type I)
 GB 5966-86 (CC₁)

Features:

- △ Application for Resonant, Coupling, Matching CKT
- △ High Stability and High Q Requirement
- △ Low Loss at Wide Range of Frequency
- △ Linear Temperature Coefficient of Capacitance

Specifications:

Operating Temp. Range	-25°C to +85°C										
Capacitance	Range	0.5 to 1000PF measured at 1MHz±10%, 1Vrms, 25°C									
	tolerance	±0.25PF (C), ±0.5PF (D), ±5% (J), ±10% (K)									
Test Voltage	<1000VDC: 3 times of Working Voltage for 1~5 seconds										
	≥1000VDC: 2 times of Working Voltage for 1~5 seconds										
Quality Factor (Q.F.)	NPO~N750, SL	C <30PF	Q ≥400+20xC								
		C ≥30PF	Q ≥1000								
	N1000, N1500	C <30PF	Q ≥200+10xC								
		C ≥30PF	Q ≥500								
Insulation Resistance (I.R.)	10000MΩ min. at working voltage for 1 minute										
Temperature Characteristic -25°C ~ +85°C (Fig.3)	Cap. change	NPO	N150	N220	N330	N470	N750	N1000	N1500	+350~	
	PPM/°C	±60	±60	±60	±60	±60	±60	±250	±250	-1000	
	EIA RS 198	C0H	P2H	R2H	S2H	T2H	U2J	V2K	W2K	S2L	
	JIS C 6423	CH	PH	RH	SH	TH	UJ	VK	WK	SL	
GB 5966-86	C	P	R	S	T	U	Q	V	SL		
Effect of Soldering	Cap. change within: ±2.5% or ±0.25PF. To be measured after 4~24 hours (Solder Temp.: 270±5°C, Dipping duration: 3±0.5 sec.)										
Life Test	Cap. change	: within ±3% or ±3PF.								Test Condition and Method: 1. Temp.: 85±3°C 2. Test Duration: 1000 hours at 2 times W.V. 3. To be measured after 1~2 hours at room temp.	
	Q.F.	: Under 10PF, Q ≥200+10C : 10PF~30PF Q ≥275+5/2C : Over 30PF Q ≥350									
Solderability	I.R. : >1000MΩ It does not remains unsoldered area over 1/4 of the circumference of the lead. (Solder Temp.: 235±5°C, Dipping duration: 2±0.5 sec.)										

Fig. 3

TEMPERATURE CHARACTERISTICS

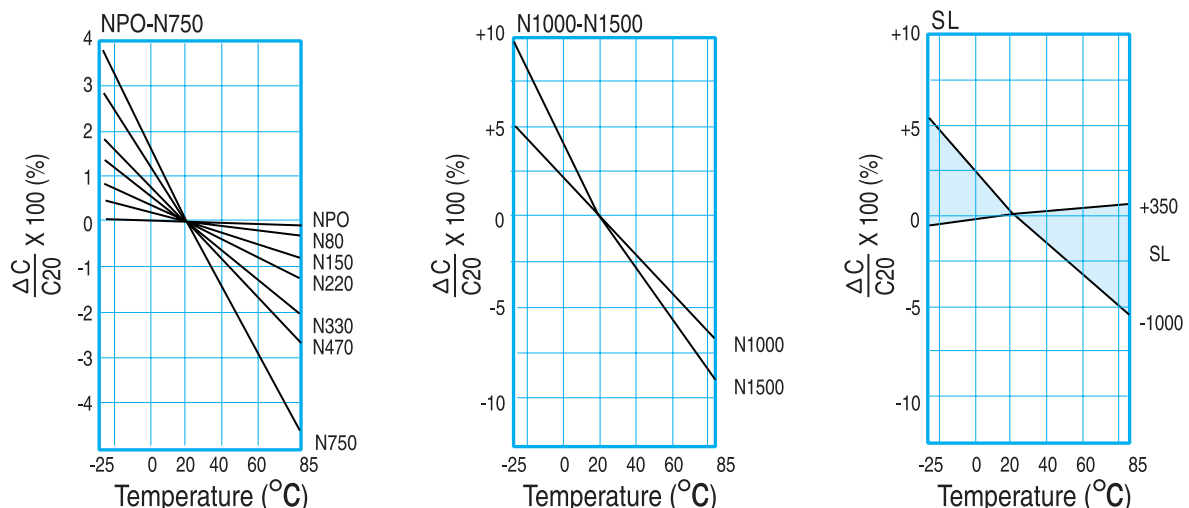



High Dielectric Constant (Hi-K) Capacitors 50 (160) ~ 6000WVDC

EIA RS 198 (Class II)
 JIS C 6422 (Type II)
 GB 5968-86 (CT₁)

Features:

- Δ Application for Band Filter, By-pass, Coupling CKT
- Δ Low dissipation factor and high insulation resistance
- Δ Freq. discriminating which Q and stability of cap. char. are not major importance
- Δ Non Linear temperature coefficient of capacitance

Specifications:

Operating Temp. Range	+10°C to +85°C for ZE, ZF		-25°C to +85°C for YA, YB		
Capacitance	Range	100PF to 0.1 UF measured at 1KHz±10%, 1Vrms, 25°C			
	Tolerance	±5% (J) for YA, ±10% (K) for YA, YB, ±20% (M) for YB, ZE, ^{+80%} _{-20%} (Z) for ZE, ZF			
Test Voltage	<1000VDC: 2.5 times of Working Voltage for 1~5 seconds				
	≥1000VDC: 2 times of Working Voltage for 1~5 seconds				
Dissipation Factor (D.F.)	2.5% Max. for YA, YB, ZE at 1KHz, 1Vrms, 25°C				
	5% Max for ZF at 1KHz, 1Vrms, 25°C				
Insulation Resistance (I.R.)	10000MΩ min. at working voltage for 1 minute				
Temperature Characteristic -25°C ~ +85°C (Fig.4)	Cap. change within	±5%	±10%	+20/-55%	+30/-80%
	EIA RS 198	Y5E	Y5P	Z5U	Z5V
	JIS C 6422	YA	YB	ZE	ZF
	GB 5968-86		2B ₄	2E ₄	2F ₄
Effect of Soldering	Cap. change within: ±3.5% (YA), ±5% (YB), ±15% (ZE), ±20% (ZF) To be measured after 4~24 hours (Solder Temp.: 270±5°C, Dipping duration: 3±0.5 sec.)				
Life Test	Cap. change: within	±5% (YA), ±10% (YB)	Test Condition and Method:		
		±20% (ZE), ±30% (ZF)	1. Temp.: 85±3°C		
	D.F. :	5% Max for YA, YB, ZE	2. Test Duration: 1000 hrs at 2 times W.V.		
		7.5% Max for ZF	3. To be measured after 1~2 hours at room temp.		
	I.R. :	>1000MΩ			
Solderability	It does not remain unsoldered area over 1/4 of the circumference of the lead. (Solder Temp.: 235±5°C, Dipping duration: 2±0.5 sec.)				

Fig. 4

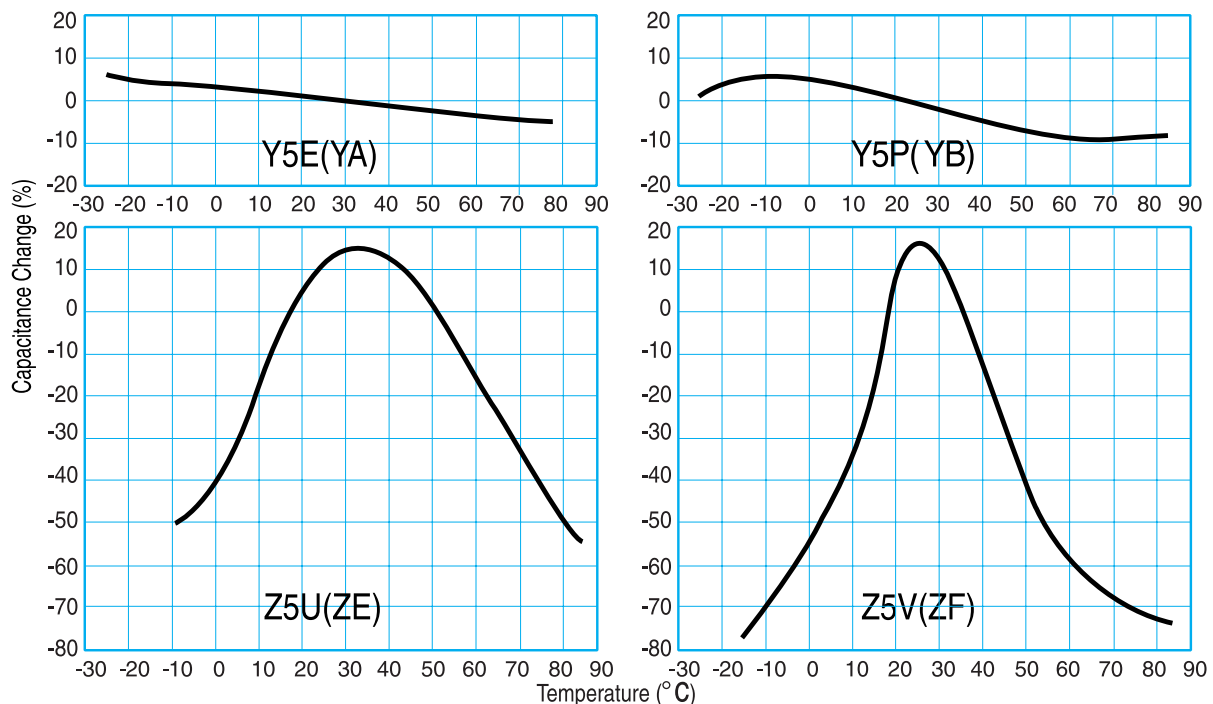



**Semi-Conductive (S.C.) Capacitors
(Surface Layer Type)**

12 (16) ~ 50 (100)WVDC

EIA RS 198 (Class III)
JIS C 6422 (Type III)

Features:

- △ Application for By-pass, Coupling CKT
- △ Frequency determination, in which dielectric losses (Dissipation Factor) and Insulation Resistance and Cap. Stability are not major importance.
- △ Large capacitance in small size (Transistorized)

Specifications:

Operating Temp. Range	-25°C to +85°C			
Capacitance	Range	0.0027 μF to 0.47 μF measured at 1KHz±10%, 0.1Vrms, 25°C		
	Tolerance	±10% (K) for YB, ±20% (M) for YB, YE, ^{+80%} / _{-20%} (Z) for YE, YF		
Test Voltage	2.5 times of Working Voltage for 1~5 seconds			
Dissipation Factor (D.F.)	16V <7% ; 25V~50V <5% at 1KHz ±10%, 0.1 Vrms, 25°C			
Insulation Resistance (I.R.)	16V >100MΩ ; 25V~50V >1000MΩ at working voltage for 1 minute			
Temperature Characteristic -25°C ~ +85°C (Fig.5)	Cap. change within	±10%	+20/-55%	+30/-80%
	EIA RS 198	Y5P	Y5U	Y5V
	JIS C 6422	YB	YE	YF
Effect of Soldering	Cap. change within: ±5% (YB), ±15% (YE), ±20% (YF), To be measured after 4~24 hours (Solder Temp.: 270±5°C, Dipping duration: 3±0.5 sec.)			
Life Test	Cap. change: within ±10% (YB), ±20% (YE) ±30% (ZF)	Test Condition and Method:		
	D.F. : 16V <10%, 25V-50V <7.5% I.R. : 16V >50MΩ, 25V-50V >500MΩ	1. Temp.: 85±3°C 2. Test Duration: 1000hrs at 1.5 times W.V. 3. To be measured after 1~2 hours at room temp.		
Solderability	It does not remain unsoldered area over 1/4 of the circumference of the lead. (Solder Temp.: 235±5°C, Dipping duration: 2±0.5 sec.)			

Fig. 5

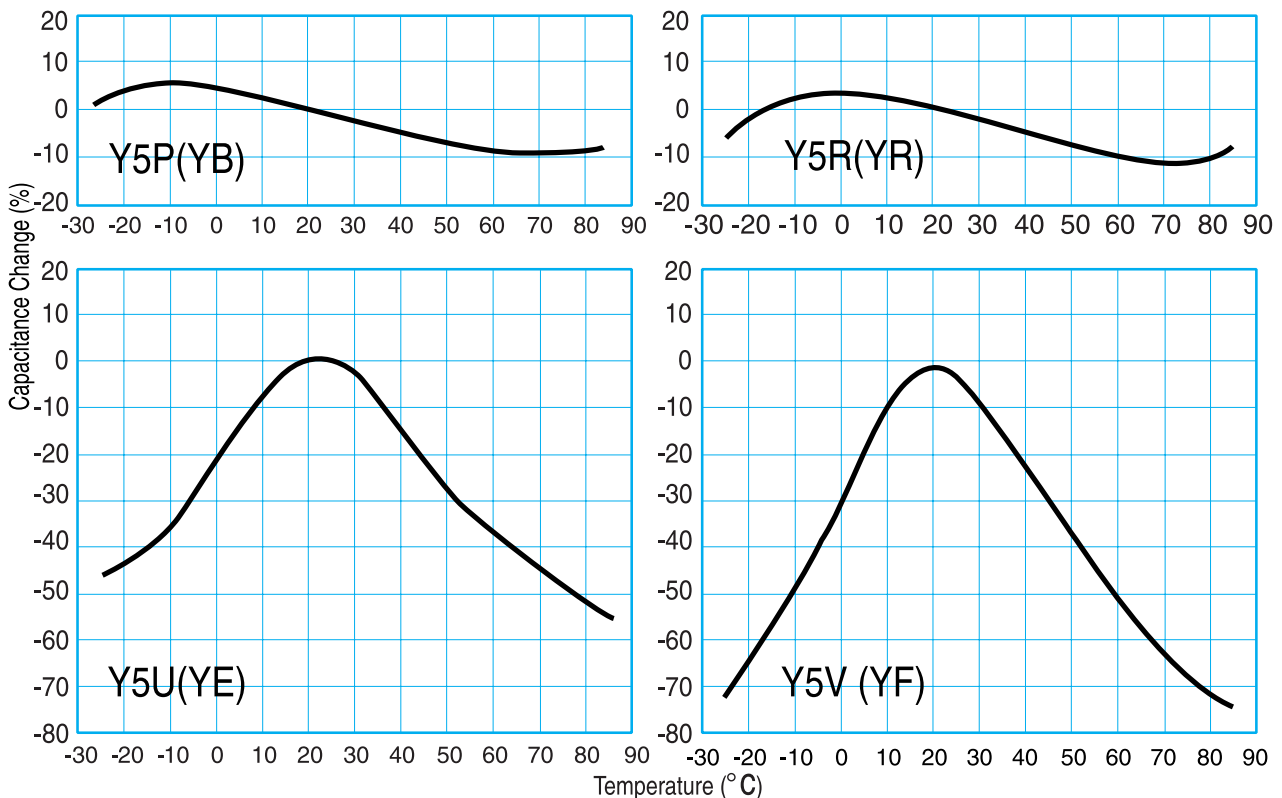



Range Chart (Capacitance in pF)

CLASS I / TYPE I / CC1

W.V.DC \ T.C.	CH NPO	PH N150	RH R220	TH N470	UJ N750	SL +350~-100	DIMENSION MAX (MM)
50V/100V	0.5-47	1-33		1-50		1-200	5.5
	50-82	34-56		51-82		200-220	6.5
	100-120	60-82		85-120		240-330	7.5
	130-180	85-110		130-180		340-470	8.5
	200-220	120-150		200-220		500-680	9.5
	230-270	160-220		230-270		820-1000	10.5
	280-330	-		-		-	11.5
	340-390	-		-		-	12.5
	470	-		-		-	14.5

CLASS II / TYPE II / CT1

W.V.DC \ T.C.	B ±10%	E +20~-55%	F +30~-80%	DIMENSION MAX (MM)
50V/100V	100-2200	1000-5600	1000-10000	5.5
	2700-3300	6800-10000	10000	6.5
	3900-4700	12000	15000, 18000	7.5
	5600-6800	15000	20000, 220000	8.5
	8200-10000	18000-22000	30000, 330000	9.5
	-	-	390000, 50000	10.5

CLASS III / TYPE III / S.C.

W.V.DC \ T.C.	YB ±10%	YE +20~-55%	YF +30~-80%	DIMENSION MAX (MM)
16V	3300-10000	3300-22000	-	5.5
	15000-22000	30000-50000	68000-100000	6.5
	22000-50000	68000-100000	150000-180000	7.5
	68000-100000	-	200000-220000	9.5
	-	220000	330000-470000	10.5
25V	3300-10000	3300-22000	10000-47000	5.5
	15000-22000	30000-50000	68000-100000	6.5
	22000-47000	68000-100000	150000-180000	7.5
	-	-	200000-220000	10.5
50V	3300-10000	3300-22000	10000-47000	5.5
	15000-22000	30000-40000	68000	6.5
	22000-33000	47000-50000	100000	7.5
	47000	68000-100000	-	8.5
	-	-	220000	10.5



Range Chart (Capacitance in pF)

W.V.DC \ T.C.	CH NPO	SL +350~-1000	B ±10%	E +20~-55%	F +30~-80%	DIMENSION MAX (MM)
500V	0.5-27	15-68	100-470	1000-1500	1000-3300	5.5
	30-47	82-100	560-1000	2000-3300	4700-5000	6.5
	56-68	120-180	1500, 1800	3900-5000	5600-6800	7.5
	82-100	200-270	2000, 2200	5600, 6800	10000	8.5
	-	300-330	2700, 3300	8200	-	9.5
	-	340-390	3900, 4700	10000	-	10.5
	-	-	5600, 6800	15000	20000, 22000	12.5
	-	-	8200, 10000	20000, 22000	47000	14.5
	-	-	-	-	100000	20.5
1KV	1-22	1-68	100-500	1000	1000-3300	5.5
	-	-	560-1000	1500-2200	4700-5000	6.5
	25-39	75-110	1200-1500	2700	5600	7.5
	-	-	1800-2000	3000-3900	6800	8.5
	47, 50	120-200	2200	4700-5600	-	9.5
	51-100	220-300	2700, 3000	6800, 8200	10000	10.5
	100-120	330-390	3300, 4700	10000	-	12.5
	150	470-560	5600, 6800	15000	22000	14.5
	220	620-750	8200, 10000	-	-	18.5
	330	820-1000	-	-	47000	20.5
2KV	1-22	1-47	100-150	1000, 1200	1000, 1200	7.5
	-	68-100	180-470	-	1500, 1800	8.5
	-	-	500-680	1500, 1800	2000-2700	9.5
	-	-	820, 1000	2000-2700	3000-3900	10.5
	-	-	1200-2200	3000-3900	4700-5600	11.5
	-	-	2700, 3000	4700-5000	6800-10000	13.5
	-	-	2700, 3000	5600	-	15.5
	-	-	3300	6800	-	16.5
	-	-	3900-5000	8200, 10000	15000	17.5
	-	-	5600, 6800	-	-	20.5
	-	-	8200, 10000	-	22000	23.5

Lead pitch v.s. body size

pitch \ DIA	≤6 Ø	7 Ø	8 Ø	9 Ø	10 Ø	11 Ø	12 Ø	14 Ø above
2.5 mm	✓							
5 mm	✓	✓	✓	✓	✓	✓	-	-
7.5 mm	-	★	★	★	○	○	✓	✓
10.0 mm	-	-	-	-	-	○	✓	✓

“ ✓ ” Standard pitch for each size. “ ★ ” Standard pitch for w.v. 2kv & above.
 “ ○ ” available for customers' requirement

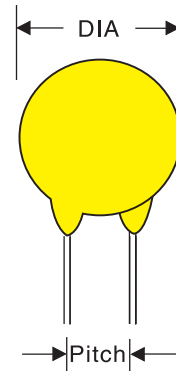

Marking principle

Line 1 : Temperature characteristic

	NPO	N220	N750	SL	Y5P	Y5U (Z5U)	Y5V (Z5V)
Code	CH	RH	UJ	S	B	E	F
Mark	Black dot	Yellow dot	Violet dot	None	B	E	F

Line 2 : Capacitance

- show with EIA code
 101=100pf 472=4700pf 104=0.1uf
 221=220pf 563=56000pf
- show actual value in pf
 which capacitance below 100pf.

Line 3 : Working voltage

Mark a bar (---) for 50V-100V
 otherwise mark the exact volt.

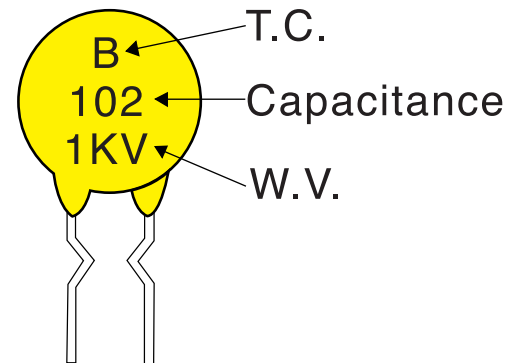

EX:

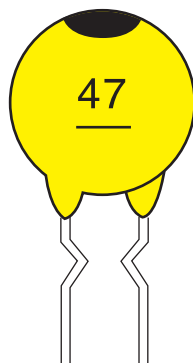

NPO
47 pf
50V

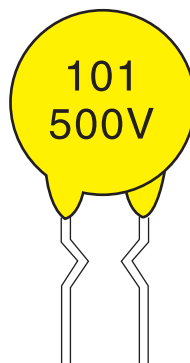

SL
100 pf
500V

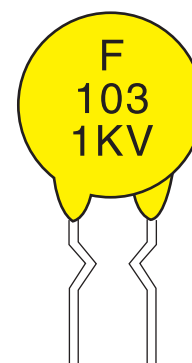

Y5V
10,000pf
1KV



Low D.F. Type

- * Low D.F performance v.s. high temperature
- * Low power loss in linear circuit "power supply" "monitor" "T.V set"

Range Chart

T.C.	D.F	Capacitance	Pitch	Dia. (mm)
Y5P (2KV)	0.5% (max)	100 - 390pF	5, 7.5	7
		470 - 680pF	5, 7.5	9
		820 - 1000pF	5, 7.5	11
		1200pF	7.5, 10	12
		2700pF	7.5, 10	15

Electrical Specification

	Specification	Test condition
Capacitance	To be within the spec tolerance.	to be measured at 25°C±1°C at 1±0.2 Vrms 1KHz
Dissipation factor	D.F.≤0.5%	
Insulation resistance	I.R.≥10GΩ	To be measured at 500 VDC
Dielectric strength	With Standing 200% W.V.	200% working voltage applied

Temperature characteristic and D.F. curves

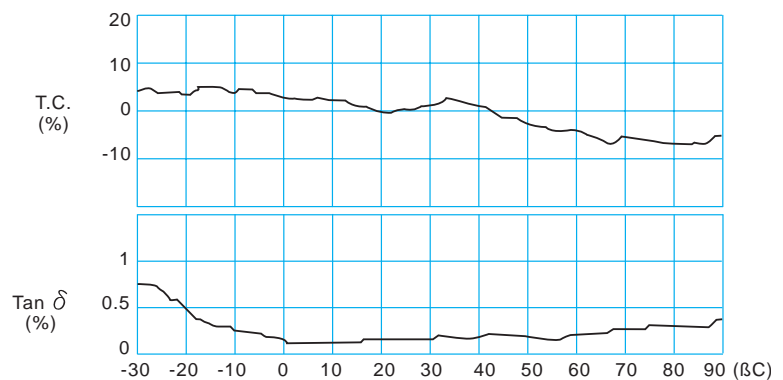

Marking Principle

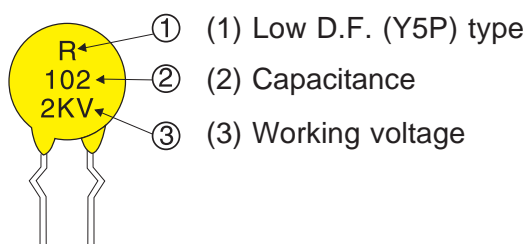

Package quantity

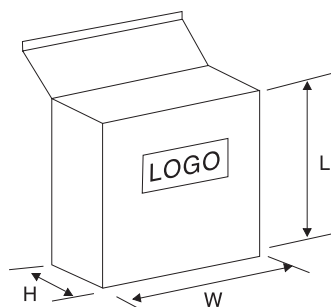

Box size: 330x250x50mm
 (W x L x H)
 Ammo : 2000pcs/box
 Bulk : 1000pcs/bag

Packing Specification

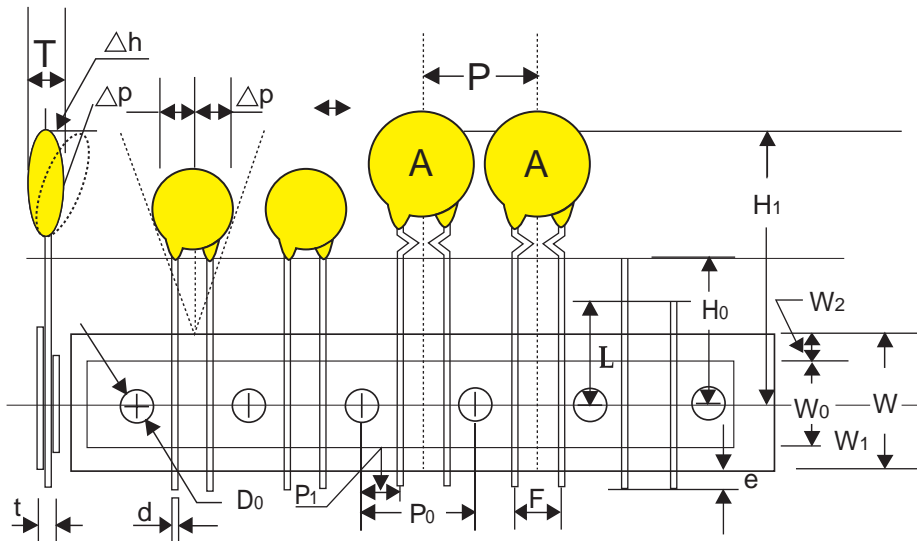

		unit:mm	unit:inch
Body Dimension	A	11.0*11.0 Max	0.43*0.43 Ref
Body Thickness	T	4.0 Max	0.157 Ref
Wire Lead Dia.	d	0.60±0.05	#24 AWG
Taping Pitch	P	12.7 Ref	0.05 Ref
Feed Hole Pitch (Note:1)	P0	12.7±0.3	0.5 Ref
Plane Deviation	ΔP	+1.0 Max	0.0394 Ref
Feed Hole Off Alignment (2e)	P1	3.81±0.7	0.15 Ref (F=5.08)
(1e)	P1	5.08±0.7	0.20 Ref (F=2.54)
Lead Spacing	F	5.08±0.5	0.2 Ref
	F	2.54±0.5	0.10 Ref
Body Inclination	Δh	0±1.0	0±0.39 Ref
Carrier Tape Width	W	18.0±1.0/-0	0.709 Ref
Adhesive Tape Width	W0	13.0 Ref	0.512 Ref
Feed Hole Ht Off Alignment	W1	9.0+0.75/-0.5	0.354 Ref
Adhesive Tape Width	W2	3.0 Ref	0.118 Ref
Straight Lead Height (Note:2)	H	20.0±0.5	0.787 Ref
Lead Crimp Height	H0	16.0 or 18.0±0.5	0.63 Ref
Top of Component Height	H1	32.0 Max	1.20 Ref
Lead End Protrusion	e	1.0 Max	0.039 Ref
Feed Hole Diameter	D0	4.0±0.3	0.157 Ref
Overall Tape Thickness	t	0.9 Max	0.035 Ref
Rejected Component Cut Height	L	10.0 Max	0.394 Ref

Note :

1. Cumnlative pitch tolerance over 20 consecutive units not to exceed ±1.0 mm
2. H=20.0±0.5 for lead style. L, Ho=16 or 18.0±0.5 mm for lead style K, I
3. Dimensions meet requirement defined in EIA RS468

Part number system

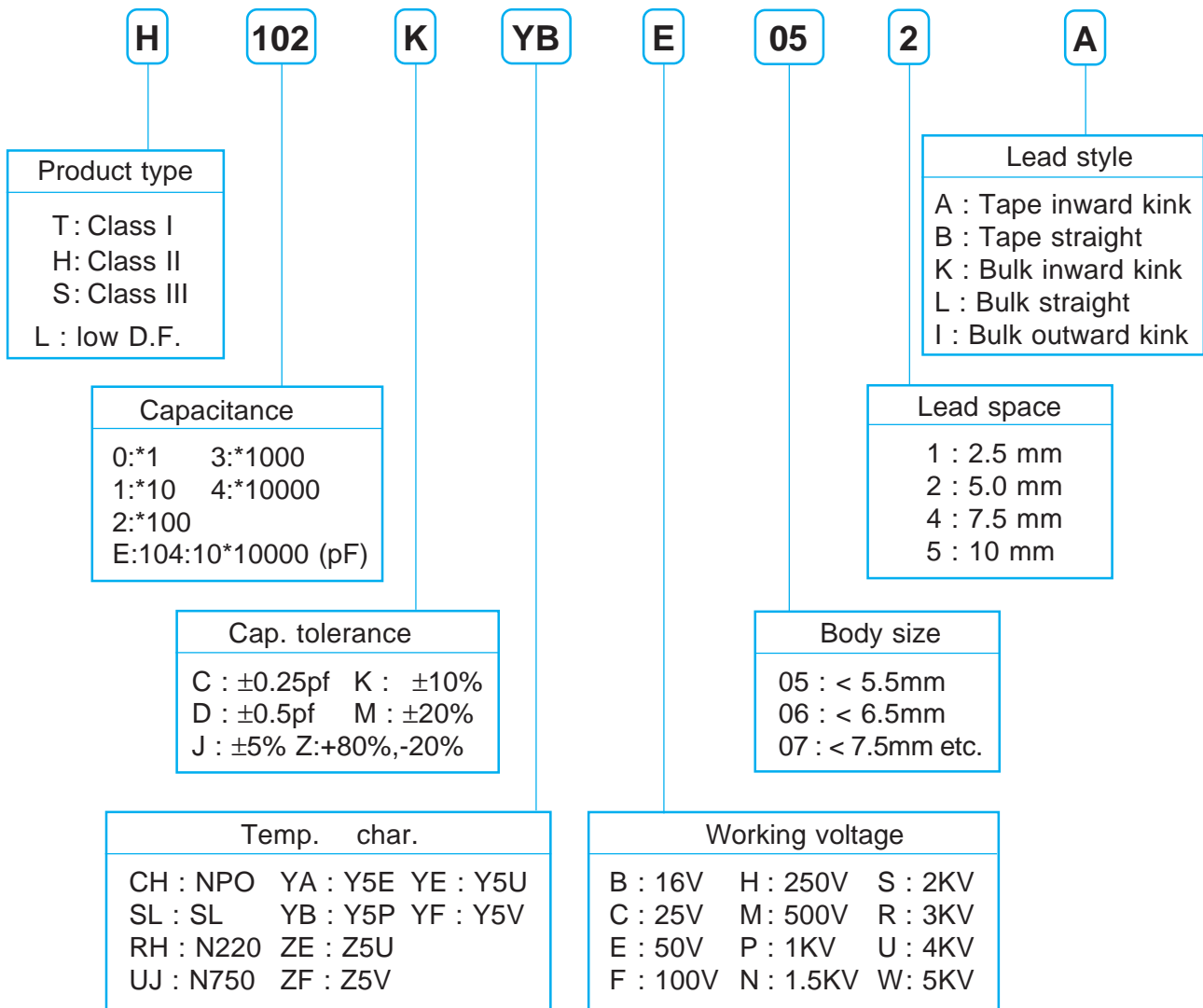

*Please contact with us if your design has a special requirement.

Lead style

Lead Style	M(max)	A
L	2 mm	5 mm ↓ 25 mm
I	5 mm	
K	5 mm	

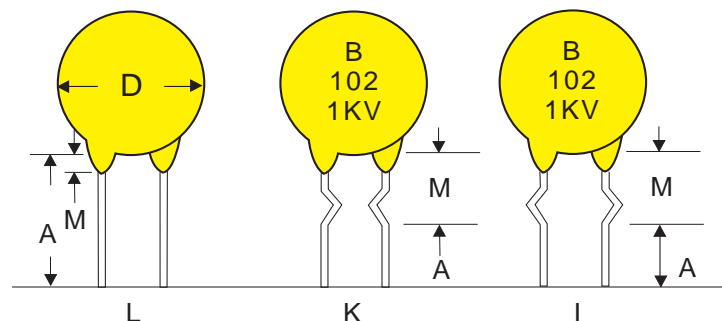

Safety standard recognized ceramic capacitor

- across-the-line
- antenna coupling
- line by-pass

Approval license and file number

Agencies	Standard NO.	Recognized File NO.	Class & W.V.	Capacitance Valuse
UL	UL 1414	E 189495, Vol.1	AC250V	101-103
CSA	C22.2NO.1	LR 111381-1	AC250V	101-103
VDE	IEC384-14 2 nd Ed.1993 EN132 400:1994	104855	X1:400V Y2:250V	101-103
FIMKO	IEC384-14 2 nd Ed.1993 EN132 400:1994	F1886	X1:400V Y2:250V	101-103
SEMKO	IEC384-14 2 nd Ed.1993 EN132 400:1994	9741064/01-02	X1:400V Y2:250V	101-103
NEMKO	IEC384-14 2 nd Ed.1993 EN132 400:1994	P97102472	X1:400V Y2:250V	101-103
DEMKO	IEC384-14 2 nd Ed.1993 EN132 400:1994	307053	X1:400V Y2:250V	101-103
SEV	IEC384-14 2 nd Ed.1993 EN132 400:1994	97,7 70742,01	X1:400V Y2:250V	101-103

Electrical Specification

Items	Specification	Testing method
Capacitance	To be within the spec tolerance.	Test at $1 \pm 0.2V_{rms}$
Dissipation factor	Y5P Y5U : 2.5% max Y5V : 5% max	1 KHz, 25°C
Insulation resistance	I.R $\geq 10G\Omega$	Test at 500VDC
Dielectric strength	To be with standing	2600VAC for 60sec

Range chart v.s. size



R.V.	CAP.	TOL.	T.C.	D.max mm	F.± 1.0 mm	L. mm	D.R. mm	d± 0.5 mm	T. mm
250 V	101 K	±10	Y5P	8	7.5	>25 (min)	<3.5	0.6	<7
	151 K	±10	Y5P	8	7.5				
	221 K	±10	Y5P	9	7.5				
	331 K	±10	Y5P	9	7.5				
	471 K	±10	Y5P	10	7.5				
681 K	±10	Y5P	10	7.5					
400 V	681 K	±20	Y5P	9	7.5				
(AC)	102 M	±20	Y5U	9	7.5				
	152 M	±20	Y5U	10	7.5				
	222 M	±20	Y5U	11	7.5				
	332 M	±20	Y5U	13	7.5				
	472 M	±20	Y5U	16	7.5/10				
	472 M	±20	Y5V	13	7.5/10				
	103 M	±20	Y5V	20	7.5/10				

Marking principle

- (1) Company's logo
- (2) Capacitance & tolerance
- (3) 7 = Year code (1997)
6 = month code
- (4) SY = safety type.

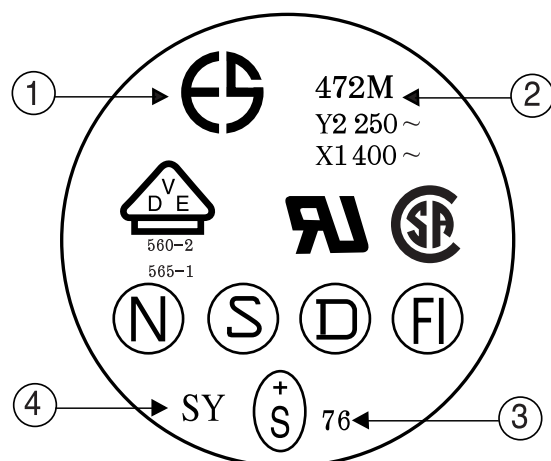

Part number system

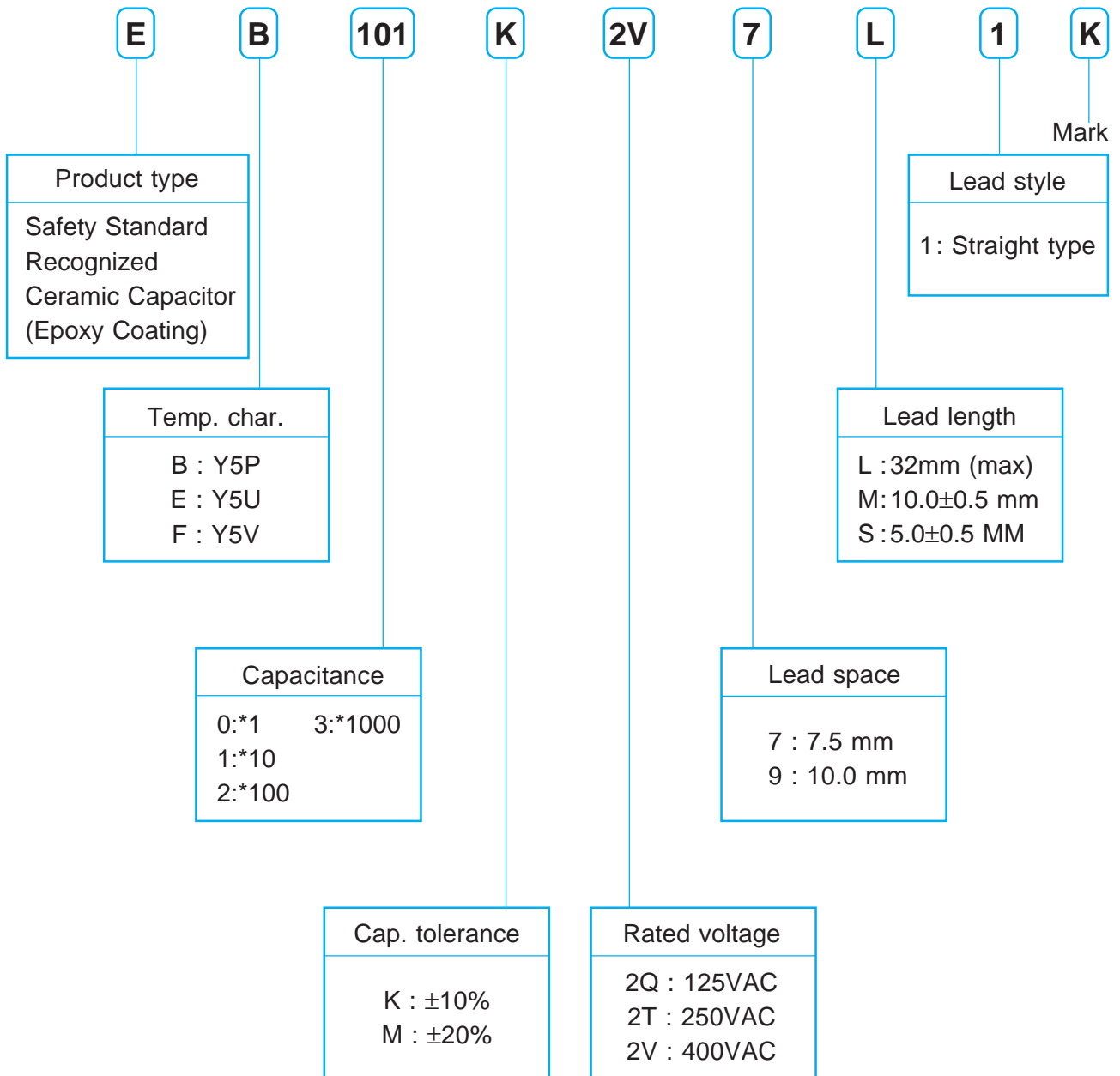

*Please contact with us if your design has a special requirement.



Notes