

PUSH
1-2 ON

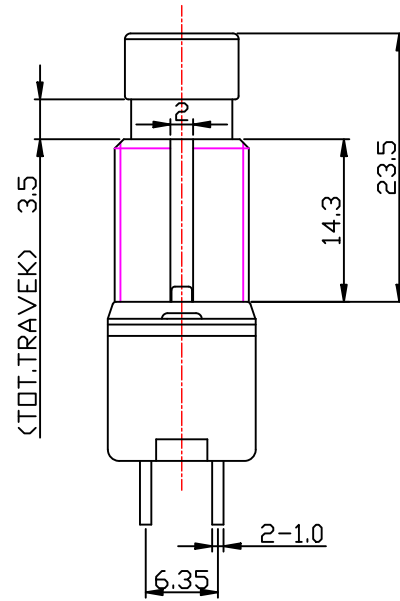
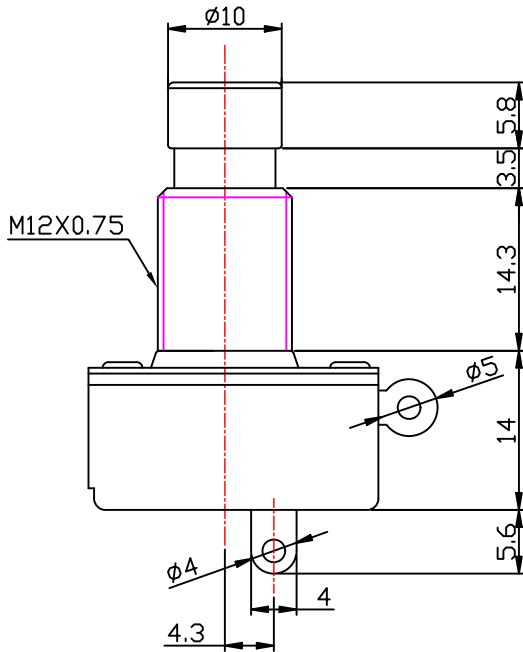

Fittings:

<input type="checkbox"/> Cu NUT ___PCS	<input type="checkbox"/> Zn NUT ___PCS	<input type="checkbox"/> WASHER ___PCS	<input type="checkbox"/> 10TEETH WASHER ___PCS	<input type="checkbox"/> PA66 WASHER ___PCS	<input type="checkbox"/> SPRING WASHER ___PCS

1			NAME	SF13N3-0102-23.5R	
2			DRAWING NO	SF13N	
3					
NO	DATE	DESCRIPTION	DRAWN BY	CHECK BY	APPROVED BY
TOLERANCE		SCALE			
less than 10 ±0.3		1:1			
above 10-30 ±0.5		DIMENSION			
above 30-100 ±1.0		mm			

型號:SF13系列

MODEL NAME:SF13 SERIES

1. 一般事項 General.

1.1 適用範圍: 此規範適用於電子機器之开关。

Application: This specification is applied to Switch used for electronic equipment.

1.2 使用溫度範圍 Operating temperature: -10~+55°C

1.3 試驗狀態: 若無特別規定限制, 則以溫度5~35°C、相對濕度45~85%、氣壓860~1060 mbar 之標準狀態測之。但對此標準狀態之測定值發生判定疑問或有特殊要求則以基準狀態。(溫度 $20 \pm 2^\circ\text{C}$ 、相對濕度 $65 \pm 5\%$ 、氣壓860~1060 mbar) 為準測定。)

Test conditions: the standard test conditions shall be 5~35°C in temperature, 45~85%RH and 860~1060 mbar in atmospheric, should any doubt arise in judgment, tests shall be conducted at $20 \pm 2^\circ\text{C}$ 、 $65 \pm 5\%$ RH and 860~1060 mbar.

2. 構造、尺寸 Construction and dimensions:

依組立圖 Refer to attached drawing.

3. 電氣性能 Electrical characteristics

NO.	項目 Items	試驗條件 Test conditions	規格 Specifications
3.01	接觸阻抗 Contact resistance	使用1KHz \pm 200Hz (最大20mV, 50mA) 及5V DC, 1A 壓降法測試 Shall be measured at 1KHz \pm 200Hz (Max 20mV, 50mA) or 5V DC, 1A by a voltage drop method.	不大於 30m Ω Less than 30m Ω
3.02	開關功率 Switch power	開關所能承受的最大電壓和電流 The switch can take maximum voltage and current	125V AC 6A 250V AC 3A 30V DC 4A
3.03	絕緣阻抗 Insulation resistance	施加500V 之直流電壓, 測試1分鐘。 測試位置: 端子和軸心間。 Applying 500V DC measure for 1 minute. Applied position: Between terminal and shaft.	100M Ω 以上 (MIN)
3.04	耐電壓 Voltage proof	施加1000V 之交流電壓, 測試1分鐘。 測試位置: 端子和外殼、端子和軸心間。 Applying 1000V AC measure for 1 minute. Applied position: Between terminal and frame. Between terminal and shaft.	不可有損傷、電弧、 絕緣破壞 Without damage to parts arcing or breakdown.

1			PREPARED BY	REVIEWED BY	APPROVED BY
2					
3					
4					
NO.	DATE	DESCRIPTION			

型號:SF13系列

MODEL NAME:SF13 SERIES

4. 機械性能 Mechanical characteristic

NO.	項目 Items	試驗條件 Test conditions	規格 Specifications
4.01	作動力 Operating force	按壓速度: 10mm/秒 操作位置: 軸心頂端 Press speed:10mm/sec. Operating position:The top of shaft.	1.2±0.3kgf
4.02	止檔強度 Stopper strength	測試時間: 按壓開關到底端10±1秒。 Test duration:Press the switch on side 10sec±1sec.	大於8kgf.cm More than 8kgf.cm
4.03	軸推拉強度 Push-pull strength of shaft	測試時間: 使用推力10秒後立即再使用拉力20秒。 測試點及方向: 測試點為軸心頂部, 方向為軸向。 Test duration:10 sec. of push force immediately followed by 20 sec. of pull force should be applied. Test point and direction:the strength should be applied to the top end of the shaft in axial direction.	大於8kgf.cm More than 8kgf.cm
4.04	軸心晃動 Shaft wobble	在距離軸心頂端5mm處施加與軸心垂直的力。 Apply force perpendicular to the shaft at the position of 5mm to be top end of the shaft.	0.7*L/30mm Max. L-軸心長度 L-shaft length
4.05	軸向間隙 Shaft play in axial	沿軸心的軸向施加5kgf的拉拔力 Apply 5kgf of force to the shaft in axial direction	0.8mm
4.06	軸套螺牙強度 Bushing nut tightening strength	軸套匹配螺母後施加扭力。 Apply torsion force for bushing matching nut	金屬軸套: 大於7kgf.cm Metal bushing: more than 7 kgf.cm
4.07	端子強度 Terminal strength	靜態負荷1kgf於端子的頂端, 測試時間為一分鐘。測試數量為一個產品的端子數。 A static load of 1kgf.cm shall be applied to the tip of the terminal in a desired direction for one minute. The number of tests shall be one per terminal.	端子無變形、鬆動 Terminal without distortion and loose

1			PREPARED BY	REVIEWED BY	APPROVED BY
2					
3					
4					
NO.	DATE	DESCRIPTION			

型號:SF13系列

MODEL NAME:SF13 SERIES

5. 耐久性 Durability

NO.	項目 Items	試驗條件 Test conditions	規格 Specifications
5.01	<p>使用壽命 (無負載)</p> <p>Operating life under no load</p>	<p>30000個週期, 運行期間不間斷, 運行速度 每分鐘9~12次。</p> <p>30,000 cycles of operation shall be performed continuously at a rate of 9~12 cycles per minute without load After operating life test ,shall be in accordance with the following specifications</p>	<p>接觸阻抗小於100mΩ 絕緣電阻大於50MΩ 耐電壓250V AC測試1分鐘 操作力不超出+10%~-30% 初始力</p> <p>Contact resistance: less than 100mΩ Insulation resistance: more than 50MΩ Withstand voltage: 250V AC per 1 minute Operating force: less than +10%~-30% for initial operating force</p>
5.02	<p>振動試驗</p> <p>Vibration test</p>	<p>把折動子停留在中間位置, 然後把電位器 放在頻率為10Hz至55Hz, 振動幅度為 0.75mm的振動試驗機上, 在X, Y, Z三個方向 來回振動, 每一個方向振動2小時, 然後在 室溫放置1至2小時測試性能。</p> <p>The brush stays in the middle position, and then the potentiometer is placed on the vibration test machine with a frequency of 10Hz to 55Hz and a vibration amplitude of 0.75mm, vibrating back and forth in X,Y, and Z three directions, vibrating for 2 hours in each direction, and then placed at room temperature for 1 to 2 hours to test the performance.</p>	<p>應無可見損傷並且標誌 清晰。不應出現開路或 短路。總電阻值變化不 應超過規定的極限值, 電阻規律符合要求。</p> <p>There should be no visible damage and clearly marked. There should be no open or short circuit. The change of the total resistance value should not exceed the specified limit value, and the resistance law meets the requirements.</p>

1			PREPARED BY	REVIEWED BY	APPROVED BY
2					
3					
4					
NO.	DATE	DESCRIPTION			

型號:SF13系列

MODEL NAME:SF13 SERIES

6. 耐候性 Weather performance

NO.	項目 Items	試驗條件 Test conditions	規格 Specifications
6.01	濕度測試 Humidity test	使用溫度 $40 \pm 2^{\circ}C$ ，濕度90~95%RH的測試條件240小時後，放置也常溫下一小時後進行測試。 Texting porentiometers being kept in the conditions at $40 \pm 2^{\circ}C$ and 90~95%RH for 240 hours in anormal ambient condition for an hour.then to be measured with in an hour.	通過以上的測試，該產品能達到以下要求： 絕緣測試:DC 500V電壓， 不小於50MΩ 耐壓測試:使用AC 250V電壓，測試一分鐘，不可有損傷、電弧、絕緣破壞,其他規格要求變化小於±20%
6.02	高溫測試 Heat test	使用溫度 $70 \pm 2^{\circ}C$ 的測試條件16小時後，放置也常溫下一小時後進行測試。 Texting porentiometers being kept in the conditions at $70 \pm 2^{\circ}C$ in temperature for 16 hours in anormal ambient condition for an hour.then to be measured with in an hour.	Through the above tests,the product can achieve: Insulation resistance: More than 50MΩ at 500V DC
6.03	低溫測試 Cold test	使用溫度 $-10 \pm 2^{\circ}C$ 的測試條件16小時後，放置也常溫下一小時後進行測試。 Texting porentiometers being kept in the conditions at $-10 \pm 2^{\circ}C$ in temperature for 16 hours in anormal ambient condition for an hour.then to be measured with in an hour.	Withstand voltage: For 1 minute or more at 250V AC,without damage to parts arcing or breakdown. Other requirements change less than ±20%.

7. 焊接耐熱性 Resistance to soldering heat

7.01	焊接耐熱性 Resistance to soldering heat	※DIP 焊錫條件: Condition of DIP soldering: 1. 清漬焊錫處理時，請確保在下列條件下作業: 1.Soldering shall be certified with following condition.		端子不可有接觸不良或明顯鬆動。 Without excessive looseness of terminals and failure contact.
		預熱溫度 Preheat temperature	(印刷基板之RV固定面溫度) 100°C 以下，2分鐘以內。 (Surface temperature of mounting side)100°C MAX Within 2 MIN.	
		焊錫溫度 Solder temperature	260°C ±5°C，5秒以內。 260°C ±5°C, Within 5 sec.	
		手焊溫度 Manual solder temperature	350°C ±5°C，3秒以內。 350°C ±5°C, Within 3 sec.	
		2. 以上工程1次通過即可。 Please use the above process only one times.		

1			PREPARED BY	REVIEWED BY	APPROVED BY
2					
3					
4					
NO.	DATE	DESCRIPTION			